

LOC		DIST		REVISIONS			
AD	00	P	L/R	DESCRIPTION	DATE	OWN	APPRO
L1				REVISED PER ECO-05-012421	01AUG06	GS	DR

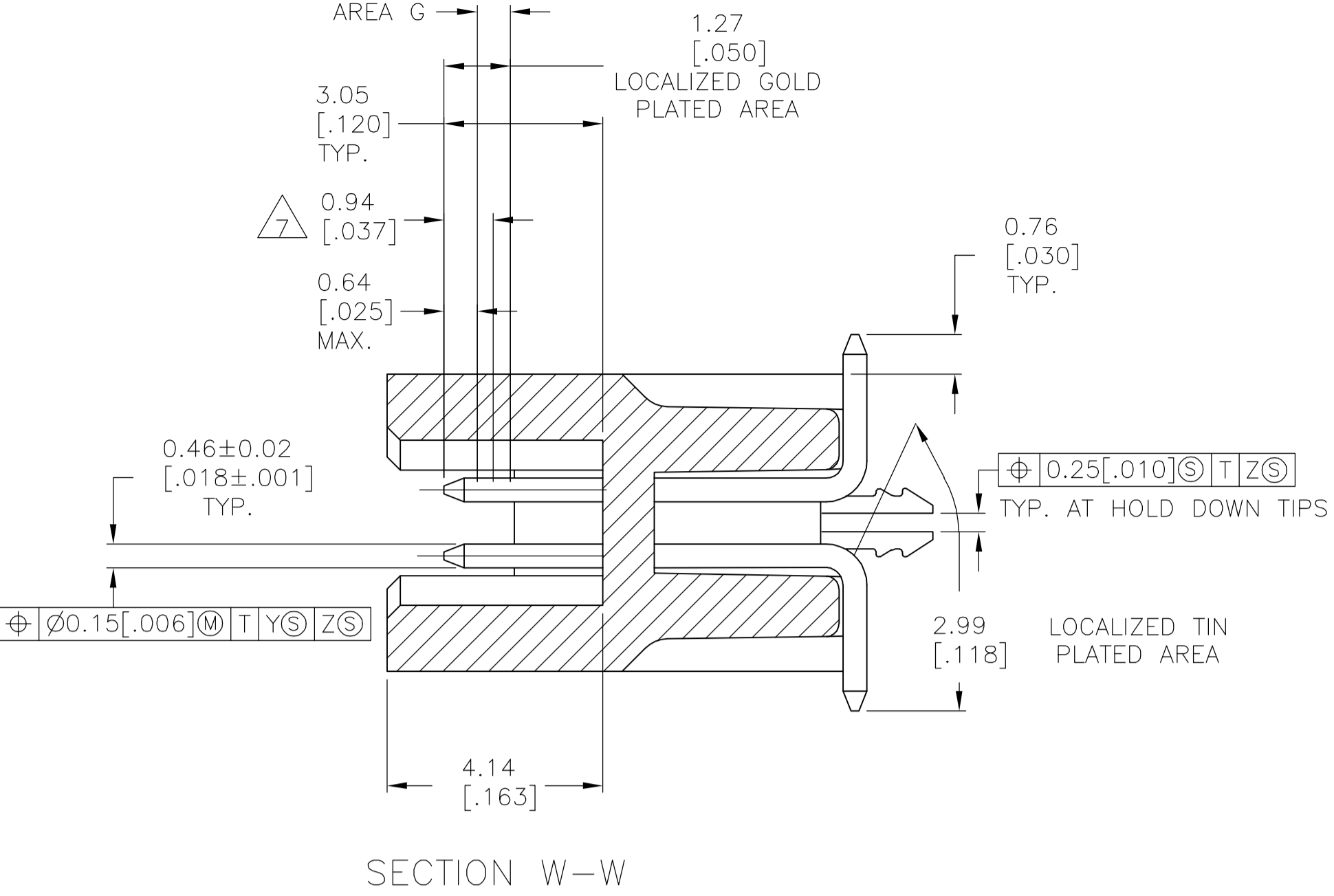

- 1 0.00076[.000030] GOLD AT POINT OF MEASUREMENT, 0.00051[.000020] MIN AT THE END POINTS OF AREA G, (LOCALIZED GOLD PLATE AREA), 0.0038[.000150] TIN-LEAD ON LOCALIZED TIN PLATED AREA, ALL OVER 0.0013[.000050] NICKEL.
- 2 USE 1.32±0.02[.0520±.0010] DRILLED HOLE (#55 DRILL). FINISH TO BE TIN-LEAD OVER 0.02 [.001] MIN COPPER.
- 3 DIMENSION APPLIES AT BASE OF SHROUD.
- 4 THE NOTED DIMENSIONS APPLY AT THE MATING FACE OF THE HOUSING.
- 5 0.0038 [.000150] TIN-LEAD ON HOLD DOWN, ALL OVER 0.0013 [.000050] NICKEL.
- 6 IF PLANNING TO USE MORE THAN ONE MATING PAIR OF CONNECTORS TO INTERCONNECT 2 BOARDS, PLEASE REFER TO SPACING PARAGRAPH IN APPLICATION SPEC, #114-7010
- 7 POINT OF MEASUREMENT
- 8 DIMENSIONS NOTED APPLY FROM THE BASIC DIMENSION LINE (NOT THE CIRCUIT CAVITY CENTER LINE) TO THE SURFACE INDICATED.
- 9 0.00076 (.000030) GOLD AT POINT OF MEASUREMENT, 0.00051(.000020) MIN AT THE END POINTS OF AREA G (LOCALIZED GOLD PLATE AREA), 0.0038(.000150) TIN ON LOCALIZED TIN PLATED AREA, ALL OVER 0.0013(.000050) NICKEL.
- 10 USE 1.32±0.02(.0520±.0010) DRILLED HOLE (#55 DRILL) FINISH TO BE TIN OVER 0.02(.001) MIN COPPER.
- 11 0.0038 (.000150) TIN ON HOLDDOWN, ALL OVER 0.0013 (.000050) NICKEL
- 12 ROHS 2002/95/EC COMPLIANT.

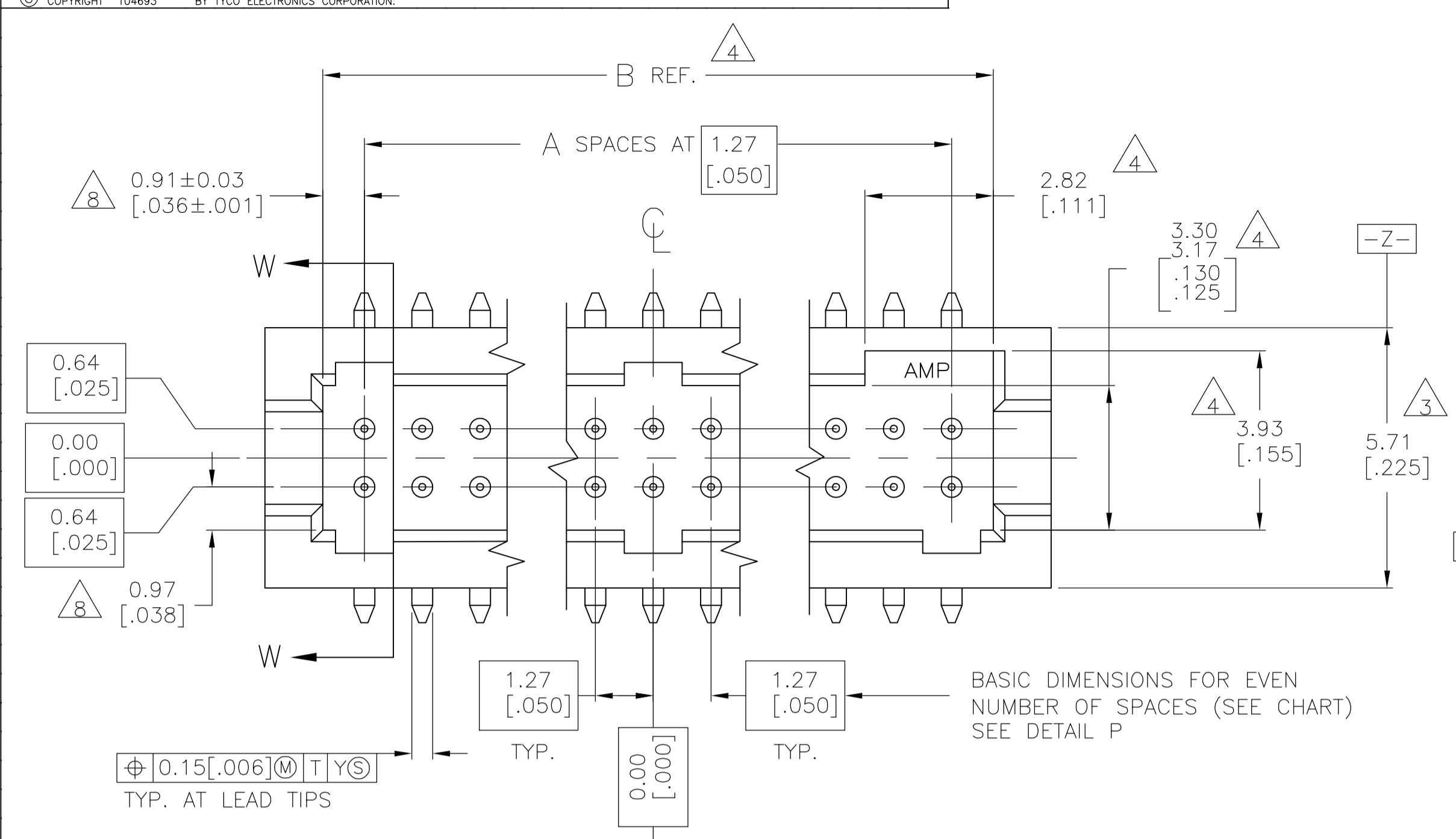
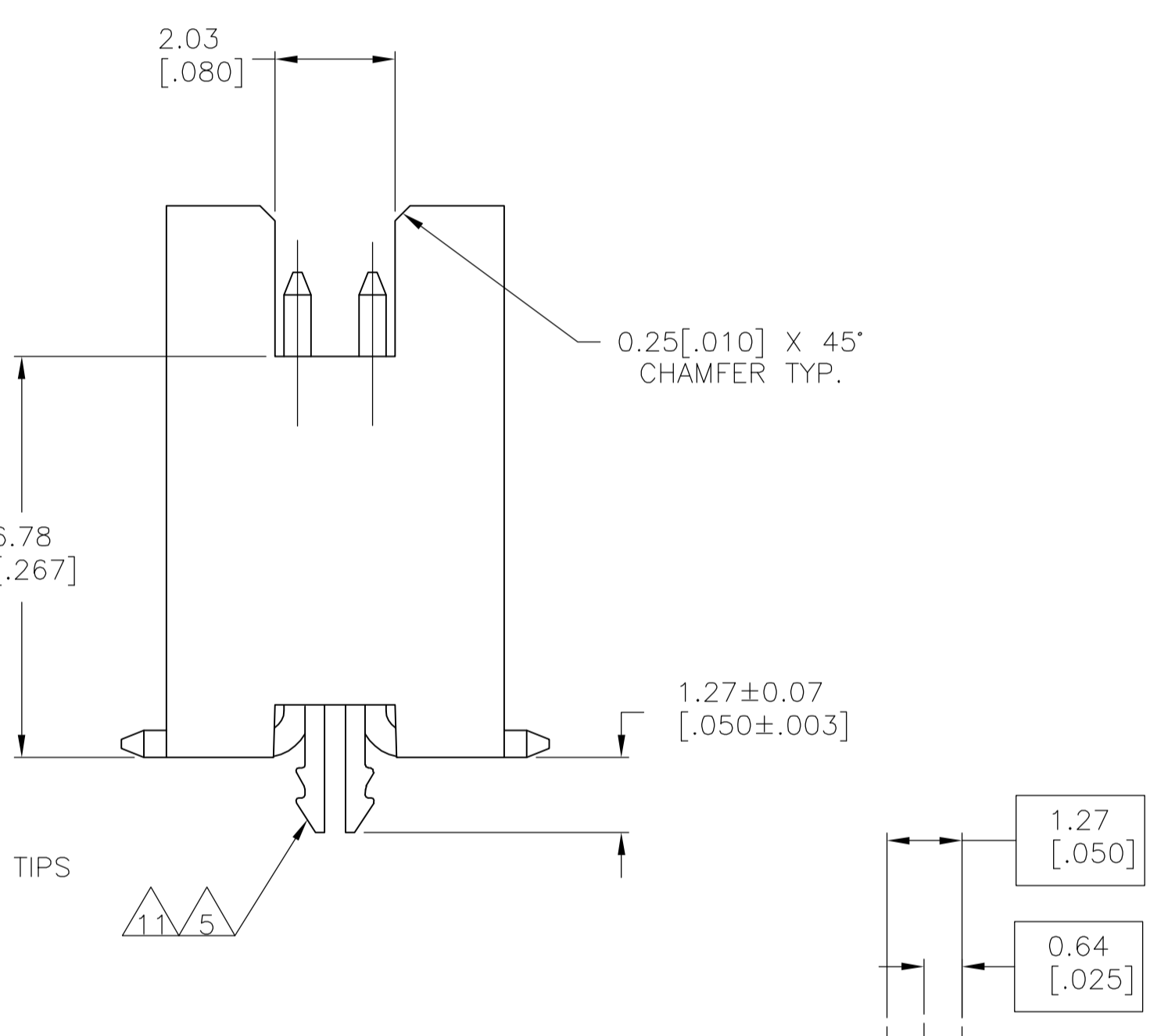
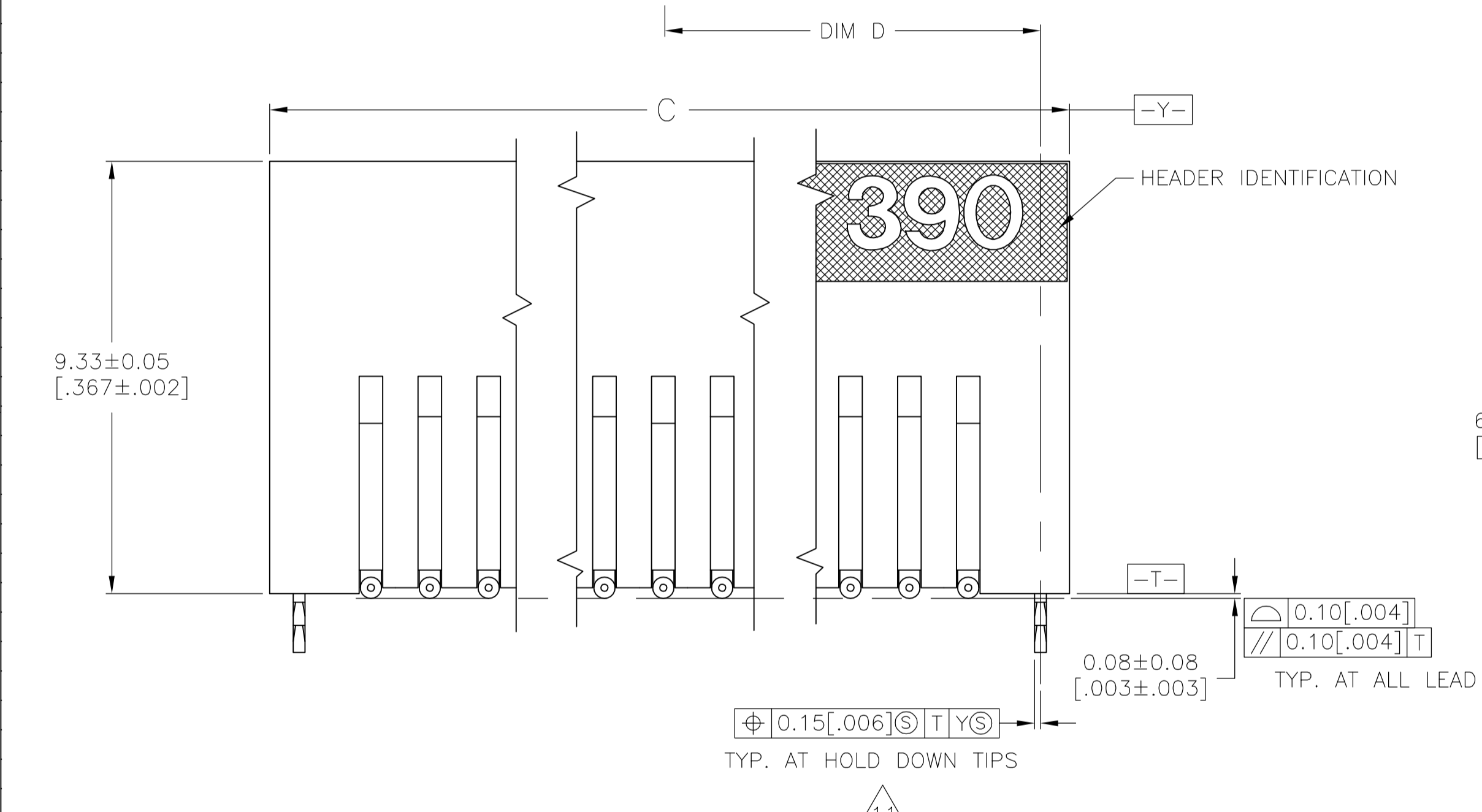

FINISH	E	D	C	B	A	NUMBER OF POSITIONS	PART NUMBER	
12	9 11	65.33 [2.572]	32.66 [1.286]	66.59 [2.622]	64.05 [2.522]	49	100	6-104693-0
12	9 11	58.98 [2.322]	29.48 [1.161]	60.24 [2.372]	57.70 [2.272]	44	90	5-104693-9
12	9 11	52.63 [2.072]	26.31 [1.036]	53.89 [2.122]	51.35 [2.022]	39	80	5-104693-8
12	9 11	46.28 [1.822]	23.13 [0.911]	47.54 [1.872]	45.00 [1.772]	34	70	5-104693-7
12	9 11	39.93 [1.572]	19.96 [0.786]	41.19 [1.622]	38.65 [1.522]	29	60	5-104693-6
12	9 11	33.58 [1.322]	16.78 [0.661]	34.84 [1.372]	32.30 [1.272]	24	50	5-104693-5
12	9 11	27.23 [1.072]	13.61 [0.536]	28.49 [1.122]	25.95 [1.022]	19	40	5-104693-4
12	9 11	20.88 [0.822]	10.43 [0.411]	22.14 [0.872]	19.60 [0.772]	14	30	5-104693-3
12	9 11	14.53 [0.572]	7.26 [0.286]	15.79 [0.622]	13.25 [0.522]	9	20	5-104693-2
12	9 11	8.18 [0.322]	4.08 [0.161]	9.44 [0.372]	6.90 [0.272]	4	10	5-104693-1
1 5	1 5	65.33 [2.572]	32.66 [1.286]	66.59 [2.622]	64.05 [2.522]	49	100	1-104693-0
1 5	1 5	58.98 [2.322]	29.48 [1.161]	60.24 [2.372]	57.70 [2.272]	44	90	104693-9
1 5	1 5	52.63 [2.072]	26.31 [1.036]	53.89 [2.122]	51.35 [2.022]	39	80	104693-8
1 5	1 5	46.28 [1.822]	23.13 [0.911]	47.54 [1.872]	45.00 [1.772]	34	70	104693-7
1 5	1 5	39.93 [1.572]	19.96 [0.786]	41.19 [1.622]	38.65 [1.522]	29	60	104693-6
1 5	1 5	33.58 [1.322]	16.78 [0.661]	34.84 [1.372]	32.30 [1.272]	24	50	104693-5
1 5	1 5	27.23 [1.072]	13.61 [0.536]	28.49 [1.122]	25.95 [1.022]	19	40	104693-4
1 5	1 5	20.88 [0.822]	10.43 [0.411]	22.14 [0.872]	19.60 [0.772]	14	30	104693-3
1 5	1 5	14.53 [0.572]	7.26 [0.286]	15.79 [0.622]	13.25 [0.522]	9	20	104693-2
1 5	1 5	8.18 [0.322]	4.08 [0.161]	9.44 [0.372]	6.90 [0.272]	4	10	104693-1

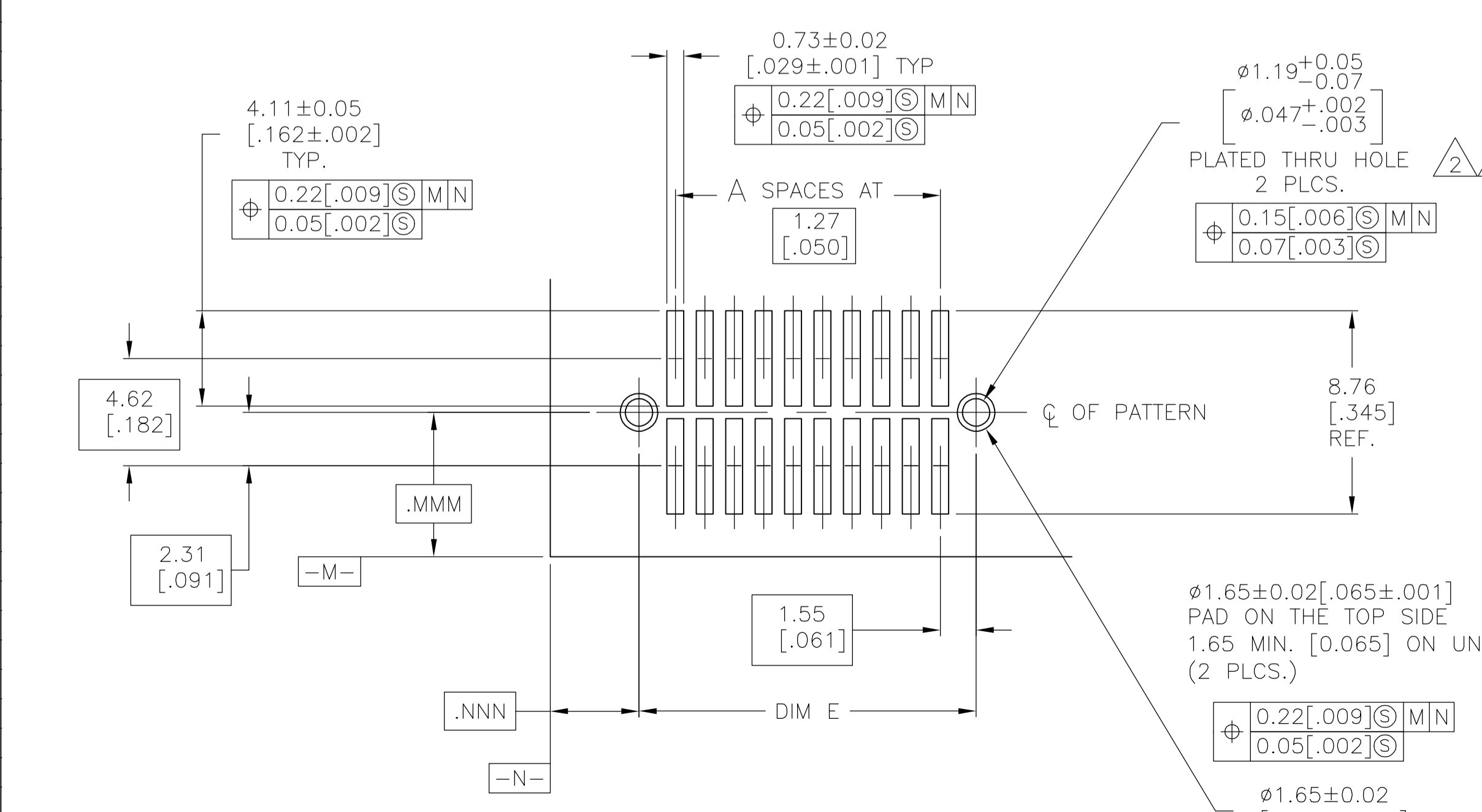

RECOMMENDED BOARD LAYOUT  
 SCALE 5:1

THIS DRAWING IS A CONTROLLED DOCUMENT.

APPROVED: KATE HELM, 8/12/91  
 CHK: D. GORENC, 8/12/91  
 NAME: D. GORENC

TYCO ELECTRONICS CORPORATION  
 HARRISBURG, PA 17105-3608

PRODUCT SPEC: 108-1332  
 APPLICATION SPEC: 114-7010

HEATER ASSEMBLY, SURFACE MOUNT, AMPMODU 50/50 GRID (9.90 [.390] MATED HEIGHT)

SIZE: A1  
 SCALE: 10:1  
 SHEET: 1 OF 1  
 REV: L1